

PREFACE

Thanks for your purchasing the motorcycle windstar 300, and sincerely welcome you to be our motorcycle user. To enjoy a more safe and pleasurable driving, at first please familiarity with the manual must carry on before driving. Your personal safety depends not only the vigilance and familiar operation skills, but also relates to whether you are familiar with the mechanical performance. Before driving, check-up and periodical maintenance are basic requirement. If maintenance and repair needed, go to our service center for help. If you know the mechanic knowledge and have the tools, the dealer can offer you help with the maintenance and repair, like providing the parts catalogue and the spare parts.

This manual explains in detail the correct operation and maintenance of windstar 300, together with the expectation for your long-time use. Modifications in specification could cause the discrepancy with some figures and content in the manual, we feel sorry for that and hold the final right of interpretation.

Have a good enjoyment and thanks again for your purchasing!

THE IMPORTANT POINTS TO ATTENTION

Ÿ The driver and passenger

This motorcycle was only used for one driver. Never exceed to the Max load capacity of the motorcycle.

Ÿ For the safety, never drive to the motorcycle in the atrocious weather or the cold weather(under -12°C)

Ÿ For the road surface:

This kind of motorcycle is only drive in the high road.

- About the caution banner with the safety or environment, stick to the sundries box cover, the rear shelf, and fuel tank cover. (Look at the clearly in the time for use or before use)
- Please carefully read the user manual

You must pay attention to the sentence or paragraph with caution banner.

Warning

Not following the operation instruction in this manual may cause great damage to you.

Attention:

Not following the operation instruction in this manual may cause injury to both you and vehicle.

Regard this manual as a permanent parts, even when transfer the vehicle to other people, transfer the manual at the same time

CONTENTS

I . Motorcycle safety driving	
Rules for safety driving	1
Payload.....	2
II .Parts Subassemblies and manual	
Parts & subassemblies	3
Meter and indicator	5
Cover, Ignition switch.....	5
Ignition switch.....	5
Fuel meter	6
Headlamp switch.....	6
Starting switch.....	6
Main beam switch	7
Turning signal light switch.....	7
Horn switch	7
Steering handle lock	7
Seat lock.....	8
Front luggage case.....	8
III.Operation guide	
checking before driving.....	9
Engine Starting	13
Driving motorcycle.....	14
Driving operation	15
Braking operation	15
Engine power off operation.....	16
Stopping the motorcycle.....	16
IV.Service and maintenance	
Periodic maintenance chart	17
Simple trouble solution.....	20
Cleaning the air filter.....	22
Battery maintenance.....	22
Adjusting idling speed	23
Replacing engine oil and cleaning strainer... ..	24
Replacing gearbox oil	25
Spark plug.....	26
Replacing fuse.....	26
Radiator maintenance	27
V.Vehicle storage.....	28
VI.Vehicle identification	29
VII.Tool set	30
VIII. Main Technique Parameter	30
IX. Circuit diagram.....	32
X . Emission Control System	
Warranty Statement	33

I . Motorcycle safety driving

Rules for safety driving

1. The motorcycle happen the many accidents, all reasons are that the car drivers didn't look at the motorcycle drivers. So the motorcycle drivers must:

- I Put up the coat in bright color
 - I Avoid to the driving at night .you must drive on guard and carefully to the strong light.
2. Particular care should be exercised at the level crossing of roads, entrance and exit of parking lot or on the automobile lane.
3. Don't speeding, because the speeding usually to happen an accident.
4. You must get to the driving license and familiar with motorcycle. Never lend motorcycle to the man without driving license or unfamiliar with motorcycle.
5. Avoid driving the road with accidental, easily result the operation failure or the part was broken.
6. Always do a pre-riding inspection before operating the vehicle. (Ref P9)
7. During driving, grasp the handle and feet on the footrest.

1

Payload

I warning:

The light goods can only put in the rear shelf or other deposited place.

The goods payload not heavier than Chart 1:

Chart 1

Deposited	Weight (kg)
Luggage	1
Rear shelf	5

※The motorcycle max payload is 200kg, including the weight with the driver, the passenger and the goods.

※If the motorcycle is over loading, it can affect the motorcycle stability and operation.

※The goods on the motorcycle must fasten.

2

II .Parts Subassemblies and manual

Parts & Subassemblies (Fig1.Fig2)



Fig 1

3



Fig2

Dashed (.....) Indicate the not see parts directly

4

Meter and indicator (Fig 3)

- (1)Water thermometer
- (2) turning signal light LH
- (3)Engine tachometer
- (4)Water temperature alarm indicator lamp
- (5)Speedometer
- (6)main beam indicator
- (7)Fuel alarm indicator lamp
- (8) Time meter & Odometer
- (9)Time regulation button
- (10)Turning signal light RH
- (11)Fuel meter



Fig 3

Cover, Ignition Switch (Fig4)

- (1)(OPEN)—Use **Key Handle** into Lock hole, turn 5 to 4 for opening Ignition Switch Lock cover.
- (2)(SHUT)—Use Key Handle into Lock hole, turn 5 to 6 for shutting Ignition Switch Lock cover.

Ignition Switch (Fig 4)

- (1) (ON)—when the switch turn to this position, Start engine and do not pull out the key.
- (2)(OFF)—when the switch turn to this position, Start engine power off and take out the key.
- (3)(LOCK)—When the switch turns to" LOCK", Take out the key .do not do any turning operation. And do not start engine and light.

Notice: If the engine is idling speed for a long time in the hot climate, It will appear too hot. Phenomenon must close engine.



Fig 4

Fuel Meter (Fig 5)

Fuel Meter (9) shows the approx remainder of flue. When The hand point to (F), it indicates Full tank of 13L. When the hand at E it indicates the remainder of flue is 2L.



Fig5

Headlamp Switch (1) (Fig 6)

Headlight switch: three position "☰", "☱" and "●"

☰: Headlamp, stoplight, position light and meter light turn on.

☱: ☱: Position light and meter light turn on.

●: Headlamp, stoplight, position lighted instrument turn off.

Starting Switch (2) (Fig 6)

Press this button to start engine. (Ref P14)



Fig6

Main beam switch (1) (Fig 7)

Press "☰" button, is high beam; Press "☷" button is low beam.

Turning signal light switch 2 (Fig 7)

When the switches on (↶), the left turning signal light turn on. When the switch on (↷), the right turning signal light turn on, Press it down the light turn off.



Fig7

Horn Switch (3) (Fig 7)

Press this button, the horn makes sound.

Steering handle lock (Fig 8, Fig 9)

Turn handle left to end, presses down ignition key 1 to (LOCK), the steering device are locked. Do the above opposite it opened.



Fig8

7



Fig9

Seat Lock (Fig 10)

- Put the key into Seat Lock Hole and then counter-clockwise direction turn to "open".
- Press Seat adown, till it make sound of locked, then push the back of seat to confirm it has been locked and take out the key.



Fig 10

Front Luggage Case (Fig 11)

- 1 Use Key 2 turn clockwise 90° for opening front luggage case 1.
- 1 Insert Key and turn clockwise 90°, push the front Luggage case closely, then turn counterclockwise 90° for closing Front Luggage case.



Fig 11

III. Operation guide

Checking before driving

For safety and prevent trouble or accident, Pre-check up is necessary everyday.

Fuel

When the pointer or fuel meter is close to red section, replenish oil; meanwhile, check the fuel tank and carburetor rack or not.

- fuel tank: 13L
- turn on fuel tank switch 1 along the arrow. (Fig 12)
- Take the key 2 Clock –wise to open the tank cover. (Fig 13)
- Suggestion gasoline: octane number is 90.
- Do not replenish fuel together with tidy or water.

NOTICE:

- The gasoline is inflammable, and can be on fire under certain conditions even exploding. Therefore, refuel should be on excellent ventilation place, and stop engine firstly. Meanwhile Smoking and lighting fires strictly prohibited when you refuel and storage.
- Refueling, don't replenish full. You should tighten the fuel tank cover.
- If swallow the oil careless, see the doctor at once.

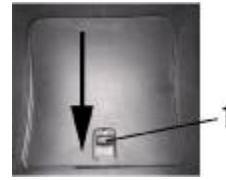

FIG 12



FIG 13

9

Checking engine oil

Check engine oil level (Fig 14, Fig15)

- 1、 Take the main stand for stand the vehicle on the ground, wring out the oil hole cover/ gauge 1, use rag to clean the gauge, and then insert gauge back. Pull out for checking oil stain.
- 2、 When the oil mass close the gauge lower limit mark 2, should add the oil, when the oil lower than upper limit mark 3, then reinsert the oil hole cover/ gauge, Screw the cover and check it is petrol dripping.

Suggestion the engine oil:

SAE-10W/40



OIL HOLE COVER/GAUGE

FIG 14



FIG15

10

Disk Brake (Fig 16, Fig 17, Fig 18)

When you can't adjust free path and see disk brake oil, please immit the disk brake oil (Fig 16, Fig 17)

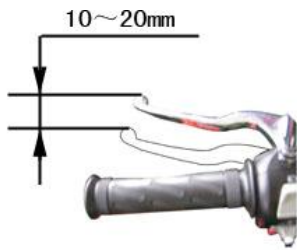

Fig16



Fig 17



Fig 18

11

Tire

Check the tire pressure regularly and adjust.

- Check when the tire cooled
- Check if there any metal trash or gravel in the groove of tires, especially, should maintenance when the tire lack.
- Inspect whether there is nick, embed nail or other tartness object on the tread or not. Inspect whether there is impress, dent or distortion for rim or not. If find any damaged, should invite service department to inspect for you.
- When the tire pattern wear and tear to the wear sign, must change the new tire.

WARNING:

- If the tire pressure dose not accord with the standard, it will properly cause the traffic accident. If the tire pressure is too low, the tire will fetch away or take of rim.
- Ÿ It is dangerous that use the worn tire; it will have effect to friction between tire and rode. Maybe difficult to drive or accident.

12

engine starting (Fig 19)

- Preparative before starting: Set up the main stand, put the key into ignition switch and turn to "ON", flameout Switch to "ON".
- Electric starter: Press start button (1) to start engine. DO not use the starter more than 5 seconds each time.

NOTICE:

- Electric starting is only in the condition of grasping the brake handle.



Fig 19

Electric starting not succeed, if starting again with it, we must stop for 30 seconds, If still can't start, Please use kick-start.

Engine kick-start: open ignition switch and add gasoline slowly, step kick-starter pedal down quickly with strength to start engine.

Notice: After using kick-starter pedal, pull it back to original position. Otherwise have effect to safety ride, and bad to engine.

Had better not open ignition switch when scooter has not use for a long time, and first step kick starter for some times. Make flue into carburetor and then into cylinder, and open ignition switch, Start engine, it is easy to start engine like this.

- If cold start warm up engine for 3 minutes.

Driving motor:

WARNING:

Wear the trousers to avoid touching with exhaust pipe and was burnt.

The entire device must be installed according to requirement of the traffic rule.

- Take the license to riding.

NOTICE:

Control the speed and load during 1000km of running in period. Load should be within 150kg (including driver) If take more weight and speed will reduce life of engine.

Speed as per Chart 2:

Chart 2

Leg (km)	0~200	200~500	500~1000
Speed (km/h)	≤30	≤45	≤55

Driving operation

- Take back Main stand and Sit on the seat, Left foot step on the ground make the vehicle and Ground upright.
- Release rear brake level, accelerate slowly with throttle grip, then motorcycle will move forward smoothly. Decelerate gradually when you stop.

WARNING

- Don't operate the throttle ON-OFF suddenly, Otherwise, the motorcycle will run out, Maybe lose control.
- Before drive, must take the stand.

Braking operation:

1. Control throttle grip

If want to reduce speed, Must control the throttle grip, at that time use the two-brake system, this point is very important.

Notice: if the drive will be done in this situation, for example: damp or loosely roads, raining .no matter brake, accelerate or turn must take care.

2. Operate front and rear brake

Notice: Must totally close the flue when drive in a descent, and use two-brake system for reduce speed. Don't uses brake continuously, other wise it will reduce the effect of brake because of too hot.

Warning: Don't use single brake when drive with high speed, special crooked and slippery road. Must use dual-brake system for avoiding accident.

Engine power off Operation (Fig 20, Fig 21)

- Turn off Throttle: Revolve to the lowest place according to picture. (Normal situation is loose the throttle grip, and the engine is idling speed)
- Put the key to "OFF"



Fig20



Fig21

Stopping operation:

When the motorcycle stop, put the key to "LOCK" position .put down stand and lock handle.(Ref P7))

Warning: Motorcycle should be park on the Solidity and Flat ground, otherwise, it maybe make some body injured or vehicle down .

Alarm points:

- Locking the handle and do not left key in the lock hole.
- Put the motor into the garage.

IV. Service and maintenance

Maintenance periodic Schedule

The maintenance is important to motorcycle, If drive with high speed in bad situation for a long time, must add the times of maintenance, If motorcycle have a big repaired or a accident, Must take it to check for mainly spare parts. For example: frame, indicator parts and so on. Repair or change the worn parts. Make sure safety.

Notice: Don't change motorcycle make sure it's safety, Must use good quality spare parts if replace spare parts .if use bad quality spare parts, it will influence the safety of motorcycle.

Warning: Must close engine when make maintenance .it make sure the repairer's safety. And put down the stand on the smooth ground.

Notice: Must make a good maintenance if the motorcycle don't use over a month, or don't use in all the winter. Make sure fuel, tire and battery avoiding corroding.

17

Periodic Maintenance Chart (Chart 3)

When you will make the Periodic Maintenance, you should inspect before driving. (Ref P9)

I: Inspect and adjust when necessary。

C: Clean

R: Replace

Chart 3

Item	Cycle	Speedometer (×1000km)				Ref Page
		1	4	8	12	
	Every Month		6	12	18	
*	Fuel Pipe		I	I	I	
*	Throttle operation		I	I	I	15
*	Air filter core	(Note 1)	C/1000km, if need: R			22
*	Spark Plug		C/2000km, If need: R			26
*	Idling speed		I	I	I	23

18

Chart 3

Item	Cycle	Speedometer (×1000km)					Ref Page	
				1	4	8		12
		Every month			6	12		18
* Transmission			Per 1000km I, If need: R					
* Gearbox oil	(Note 3)	(300km) R			I		25	
Brake system			I	I	I	I	11	
Brake Switch				I	I	I		
* Headlamp				I	I	I		
* Suspension				I	I	I		
* Bolts&Nuts tighten	(Note2)		I		I			
* Wheel, Tire				I	I	I	12	
* Turning bearing			I			I		

*If you have all of tool and maintenance document, you are a mechanic person, or else must let special person maintenance and repair.

*For safety, we claim all of items have done by mechanic person.

Note: 1.If this area is very damp or have a lot of dirty .you had better make a short time

2. If it was used on accidental road every day, must make maintenance.

3. According to season to change

SIMPLE TROUBLE SOLUTION (CHART 4)

Chart 4

Complaint	Symptom and possible causes		Remedy
Engine does not start	Plug not sparking	Damaged spark plug	Replace
		Damaged Ignition Coil	Replace
		Defective CDI	Replace
		Defective ignition switch	Replace
		Renegade or loosely Ignition system	Connect well or tighten
	Spark plug is weak	Spark plug gap too small or big	Adjust
		Spark plug pole burn	Replace
		Spark plug accumulates carbons	Clear out
	No mixed air in cylinder	Fuel use out	Replenish
		Oil mouth stop up	Dredge
		Fuel tank switch wear	Change
		Fuel path stop up	Dredge
		Air filter stop up	Clean the air filter element
Cylinder compresses strength low	Intake system leak	Check and clear out	
	Spark plug seat leak	Tighten spark plug	
	Cylinder cover leak	Change washer	
	Piston ring & cylinder wear badly	Change piston or cylinder	

Complaint	Symptom and possible causes	Remedy
The vehicle is unable to accelerate performance badly	Octane value of the fuel is too low	Change fuel
	Oil path stop up	Clean oil path
	Ignition time is too early or too late	Check coil and change CDI
	Spark too weak or flameout	Check ignition and clear out
	Mixed air too dense or race	Clean& adjust carburetor
	Engine leak	Check and clear out
	Muffler stop up	Dredge
	Belt wear	Replace
Electric start failure	Automatic clutch roller wearing	Replace
	Clutch worn	Replace
	Starting relay worn	Replace
Driving unsteady	Electric quantity lack	Charge
	Turning bearing gap too wide	Adjust
	Lack of tire pressure	Pump
Brake Failure	Front& rear Axle flexible	Tighten nut
	Brake pad fray to limit	Replace
	Brake cam fray	Replace
	Brake cable damaged	Replace
	Free path overlong	Adjust

Cleaning Air Filter (Fig 22)

- Take apart the bolt of air filter cover.
- Take out filter element.
- Compress air or use dry brush to clean filter element.
- Do the above opposite to reinstall the air filter.

NOTICE:

- Do not use gasoline or low burning point solvent to clean paper filter element.



Fig22

Battery maintenance (Fig 23)

It is adopted the airtight battery (don't add water)

Notice: Do not take apart the airtight

- If the motorcycle have not been used for a long time. Taking off the battery and putting it into a dry and place。
- The head of battery was corroded, please take it off and clean. (Can use boil water)

NOTICE: turn off the ignition switch, take apart negative pole \ominus first, but install positive pole \oplus when you are installing.



Fig 23

Adjusting idling speed (Fig24, Fig25)

The carburetor is in the best situation before sale, if the carburetor is still influence riding. Please adjust it under the instruction of professional man.

- Warm up few minutes before start
- Adjust idle screw (1) to improve idle speed slightly to enter to fasten, withdraw it than screw slowly after stocking to fasten to mix and then rapidly, to stabilizing the position at most, then withdraw slowly, get and stabilize the position the lowest.
- After adjust idle, then adjust accelerograph handle to free path for 2-4mm, then use adjustor (2) to adjust, screw down nuts, and then screw up it after adjust.
- Adjusting the idle speed, it should be able to suddenly strengthen the throttle, the rotational speed of the engine should be excessively steady, no temper and flameout, stop working or arrange organ not to flameout at being last throttle.



Fig24



Fig25

Replacing engine oil and cleaning strainer

Replacing engine oil (Fig26)

Suggestion engine oil: SAE 15W/40

- Checking the engine oil before engine cold, and under the condition of steady of motor.

Cleaning strainer

- Take out oil hole cover and oil filter (1) then take strainer (2) and spring (3).
- Using liquor clean the strainer.
- Install oil filter then take strainer and spring.
- Replenish the standard engine oil to upper limit line of the oil hole cover.
- Install the cover of hole and liter.
- Start engine and keep for few minute then flameout..
- Measure the lever of engine oil again, makes sure it is not leak.



Fig26

Replacing gear oil (Fig 27, Fig28)

Suggestion gear oil: SAE 80W/90

Oil container

replacing capacity: 0.18L

- Make the motorcycle on the stand
- Take apart the immiting bolt (2), and the spilling bolt (1)

NOTICE: The engine must be warmer when spilling and the vehicle must be steady by main stand. Make sure the Engine is empty

- Reinstall the spilling bolt after clean. and screw up.
- Inject 180ml to engine through immit bolt
- Install immit bolt and screw up.

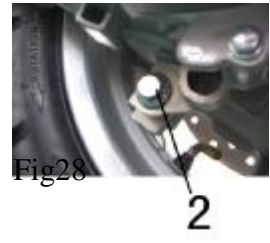

25

SPARK PLUG (FIG 29)

Specification of Spark Plug: DPR7EA(NGK)、D7RTC OR DPR6EA

- Disconnect the spark plug cap, and then use the special handle to remove spark plug.
- Check if the spark plug electrodes and the center porcelain head burned accumulative carbon, etc.
If the spark plug is burned out, replace new spark plug.
- Adjust the spark plug gap between (0.6~0.7) mm .
- Don't use an unspecified spark plug.

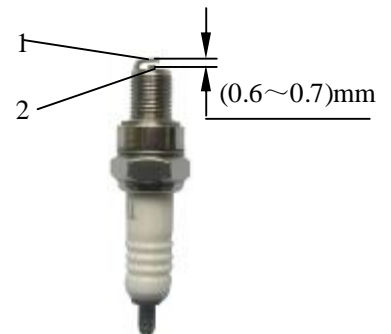

Fig29

Replacing fuse

The specified electric current of the total fuse is 15 A, which is in Battery.

If the connection is not good, the fuse will overheat and breakdown.

Do not use brass wires to replace the recommended.

26

Radiator Maintenance

Suggestion Cooled liquid Type: anti-freeze liquid

It's only using antirust antifreeze liquid for this engine.

Take the right cover of footrest, check the liquid lever should be 1/5, if less than 1/5, please add it.

Adding the cooled liquid

• Clockwise open the cover 1 of radiator, if the cooled liquid is not full, please keep it full, and then cover it.

• if you want to add more cooled liquid, starter the engine liquid rising 80°C, waiting for 5minuts then open the cover 1, till the liquid full, close the cover.

• As per above order, you can add the 3rd liquid.

• You can open the cover 2 to immit the liquid after the engine is cooled also.

Warning:

When the engine is high temperature, do not open the cover, in case the liquid burst out to injury somebody..

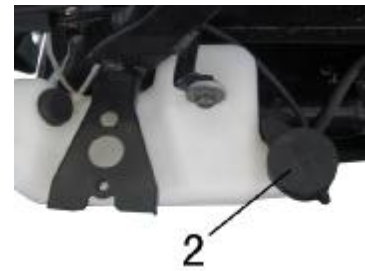

Fig31

V. Vehicle storage

Storage

For store up the motorcycle for a long period of time, for example, in wintertime, some steps should be taken to prevent malfunction of and damage to its components, which might be caused by long storage. Besides, before the long storage, proper maintenance has to be carried out for fear that it might be forgotten when vehicle is put back into use after storage.

1. Change engine oil.
2. Drain off fuel from the fuel tank and carburetor.

Warning: Gasoline is inflammable and may cause fire and even explosion under certain conditions. Therefore, do not smoke, make fire or have any fire left behind on draining off fuel.

- Take out the spark plug, pour about 15~20ml clean engine oil into the cylinder, step down the kick lever repetitively for several times so as to have machine oil distributed all over the engine and finally fit the spark back on.
- Remove battery, batter can't be kept on icing and direct sunshine location, charge every month.
- Wash the motor, wipe it dry and apply an even coat of wax to the painted surface. Antirust can prevent the surfaces from rusting.
- Put the vehicle in a shady and cool place far from humidity and direct sunshine and cover it properly (but not with plastic or other painted materials).

Reuse motorcycle.

Take down the motorcycle cover and clean the motorcycle, if the storage time exceeds 4 months, Must change engine oil.

Must charging if need, and then install battery.

Must check all of terms before drive (Page9) for the safety must try the motorcycle with lower speed for some time in a not busy rode.

VI. Vehicle identification

Type, VIN and nameplate position (FIG 32)

When the motorcycles are registered or getting the license from the transport department, the owner should be send the VIN number and engine number. The maintain people change the parts, need the numbers too.

The products brand should be added at the right side plate of the main stand (see P3)



Fig32



Fig33

29

VII. Tool set

Tool bag(Fig 34)in the boot of seat, Using for the urgent accident when driving, it including the something of the following:

8×10mm spanner 12×14mm spanner Screw drive
Hexagon spanner Wrench bar 18.5×17mm wrench spanner



FIG34

VIII. MAIN TECHNIQUE PARAMETER

CHART 5

Item	Parameter		Item	Parameter
L×W×H mm	2160×760×1210		Front Tyre	130/70-12
Wheelbase mm	1540		Rear Tyre	130/70-12
Ground Clearance mm	125		Air Pressure, Fr wheel kPa	200
Dry weight kg	155		Air Pressure, Rr wheel kPa	250
Max Load kg	200		Transimission system	CVT
Turning angle of steering handle	≤48°		Gear ratio	5.12~15.05
V=60km/h	Front brake distance	Fr brake average deceleration	Rear brake distance	Rr brake average deceleration
	≤37.3m	≥4.4(5.8) m/s ²	≤54m	≥2.9(5.8) m/s ²
Brake Distance m	≤7(30km/h)		Engine Type	173MM, single Cylinder 4 stroke, water-cooled
Max Speed km/h	≥85		Bore×stroke mm	72.5×66.8
Consumption L/100km	≤3.1		Displacement ml	275.8

Chart 5

Item	Parameter	Item	Parameter
Climb ability °	≥18	Clutch	Automatically centrifugal
Lean	-1.3%	Fuel tank L	13
Starting system	Electric	Battery	12V 9Ah
Lubricate System	Press & splash	Fuse	15 A
Rated Power	12.2 kW/7000 (r/min)	Headlight	12V35W/35W×2
Max Torque	18.5 N.m/5000 (r/min)	Taillight/Brake light	12V 21W/5W
Compression ratio	10: 1	License light	12V 5W
Spark Plug Model	DPR7EA(NGK)、D7RTC OR DPR6EA	Turning light	12V 10W
Spark plug gap mm	0.6~0.7	Fuel trademark	RQ90 Above
Valve Clearance mm	0.1 (cold)	Ignition System	CDI
Idling speed r/min	(1500±150)r/min	Gearbox oil	SAE 80W/90
Capacity of engine oil	1.1L	Capacity of Gearbox oil	0.18L
Engine oil	SAE 10W/40		

IX. Circuit Diagram

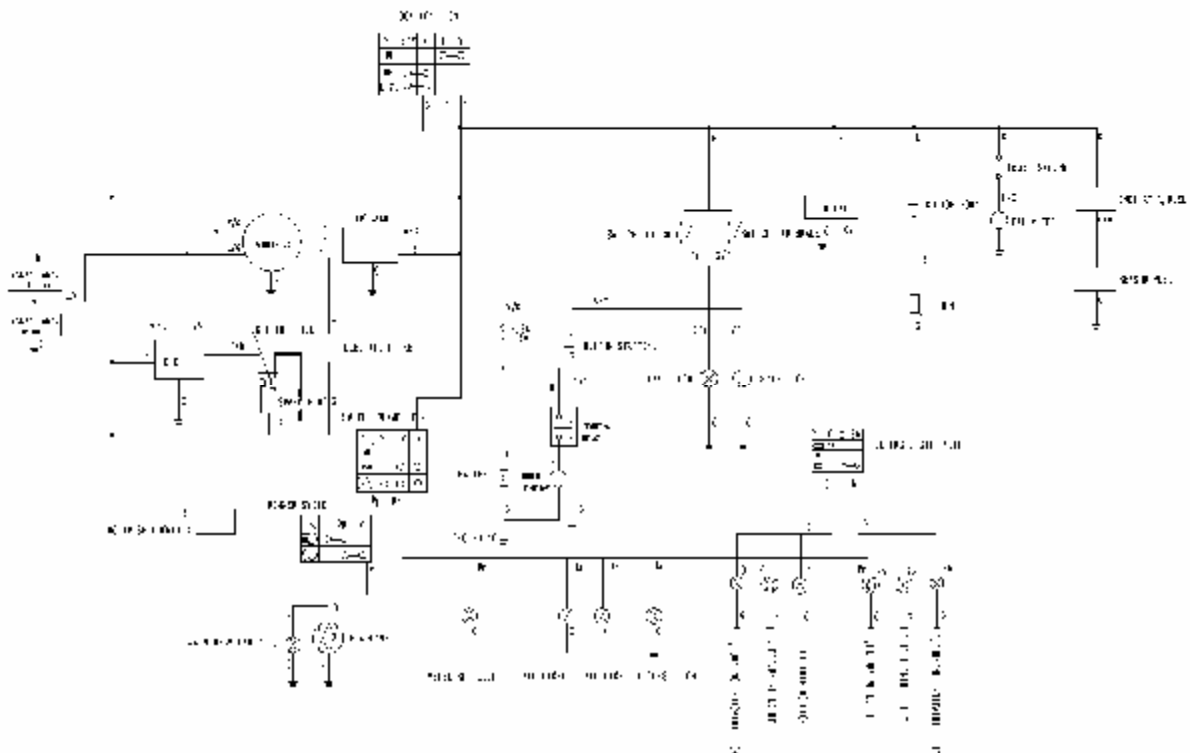

X. Emission Control System Warranty Statement

Wangye USA Co., LLC is pleased to explain the emission control system warranty on Highway Motorcycle. New Highway Motorcycle must be designed, built and equipped to regulations and standards of the United States Environmental Protection Agency and the California Air Resource Board and free from defects in material and workmanship that may keep it from these requirements in the all applicable regulations.

Wangye USA Co., LLC must warrant the emission control system on the highway motorcycle for 5 years or 18,000 km, whichever comes first, provided that there has been no abuse, neglect or improper maintenance of highway motorcycle.

1. Period of Warranty

The period of warranty shall be one year on delivery, during this period of warranty:

- (i). Any part defective by reason of the manufacturer's faulty workmanship or material will be replaced or repaired free of charge;
- (ii). Any repairs or adjustments made necessary by reason of the manufacturer's faulty workmanship or material will be performed free of charge.

Emission control system may include parts such as the carburetor or fuel injection system, the ignition system, catalytic converter and engine computer, if it is equipped. Also included may be hoses, belts, connectors and other emission-related assemblies.

2. Responsibilities of Customer

To obtain repairs under warranty, the customer must:

33

- (i). Ensure that the motorcycle is properly operated, maintained and stored as specified in the Owner's Manual;
- (ii). Give notice to dealer approved by Wangye USA Co., LLC or other qualified service facility of any and all apparent defects immediately upon discovery, and make the entire motorcycle available at the time for inspection and repair at the dealer's place of business;
- (iii). Provide proof of warranty coverage to dealer;
- (iv). Authorize the dealer to tear down the motorcycle for diagnostic evaluation should it be required.

All warranty repairs must be done by the dealer and final approval of any repairs rests with Wangye USA Co., LLC. All parts replaced become the property of Wangye USA Co., LLC.

3. Exclusion

This warranty does not cover the repair or damage resulting from abuse or neglect of the motorcycle. Examples of abuse and neglect include, but are not limited to:

- (i). Racing and competition;
- (ii). Use of lubricants, oils and fuel/oil mixture other than those recommender in the Owner's Manual, improperly installed accessories and use of parts or accessories that are not equivalent in design and quality to genuine Wangye parts;
- (iii). Damage as a result of accidents, collisions, contact with foreign materials, impact, submersion or use of the motorcycle after discovery of a defect;
- (iv). Appearance-related damages of body parts. Examples of such damages include but are not limited to: scratches, dents, fading, flaking and peeling;
- (v). Motorcycle which has been modified in any way from the standard specifications shown in the Owner's Manual, for example, the odometer has been altered;
- (vi). Normal wear and tear, corrosion and routine maintenance, such as the recommended service inspections;

34

- (vii). Pre-delivery inspection and assembly;
- (viii). Damage from theft, fire, vandalism, explosion, water or acts of God.

4. Restriction

This warranty is in addition to, and not a modification of, any legal warranty required by the laws of any state of US.

Subject to any applicable sales or consumer legislation, the above warranty is in lieu of any warranty or representation, express or implied, including any warranty of performance, merchantability or fitness for a particular purpose on the part of Wangye USA, and any other obligation or liability on behalf of Wangye USA, and the above warranty constitutes your sole remedy and the full liability of Wangye USA. In no event shall Wangye USA be liable for special, incidental or consequential damages howsoever caused, whether by negligence or otherwise resulting directly or indirectly from the use of the Motorcycle, or the Motorcycle's having replacement parts or the unavailability of replacement parts. Wangye USA does not assume or authorize any person to create or assume for Wangye USA any obligation or liability in connection with the Motorcycle or any part thereof distributed by Wwangye USA.

5. Contact

For any questions regarding emission control system warranty, please contact as following:

Company Name: Wangye USA Co., LLC

Address: 1170 Corporate Dr. West Ste. 204, Arlington, TX 76006

Tel: 817-640-1108 ext 219

Fax: 817-649-5006